

Iterative methods for random sampling and compressed sensing recovery

Masoumeh Azghani
ACRI and EE Dept.
sharif university of Technology
Tehran, Iran
Email:azghani@ee.sharif.ir

Farokh Marvasti
ACRI and EE Dept.
sharif university of Technology
Tehran, Iran
Email:Marvasti@sharif.edu

Abstract— In this paper, two methods are proposed which address the random sampling and compressed sensing recovery problems. The proposed random sampling recovery method is the Iterative Method with Adaptive Thresholding and Interpolation (IMATI). Simulation results indicate that the proposed method outperforms existing random sampling recovery methods such as Iterative Method with Adaptive Thresholding (IMAT). Moreover, the suggested method surpasses compressed sensing recovery methods such as Orthogonal Matching Pursuit (OMP) in terms of recovery performance. We propose a compressed sensing recovery method, named Iterative Method with Adaptive Thresholding for Compressed Sensing recovery (IMATCS). Unlike its counterpart, Iterative Hard Thresholding (IHT), the thresholding function of the proposed method is adaptive i.e. the threshold value changes with the iteration number, which enables IMATCS to reconstruct the sparse signal without having any knowledge of the sparsity number. The simulation results indicate that IMATCS outperforms IHT and OMP in both computational complexity and quality of the recovered signal.

I. INTRODUCTION

Sparse recovery methods have found broad applications in various areas such as imaging systems, multipath channel estimation, spectral estimation, and coding. Depending on various kinds of sparsity (low pass, high pass, or random) and various sampling techniques (uniform or random), different methods have been suggested in the literature for reconstruction of sparse signals [1]. When the location of sparsity is known, the number of samples required for exact reconstruction equals the sparsity number. Some of the recovery methods in this case are suggested in [1]. When the location of the sparsity is unknown, the number of samples must be at least twice the sparsity number to identify both the locations and the values of the coefficients[2]. More sophisticated recovery methods are required in this case which can be grouped based on the sampling strategy. One sampling strategy is to take linear combinations of the signal entries which is the focus of the Compressed Sensing (CS) techniques. The second sampling scheme is to take random samples of the signal entries. In CS [3, 4], linear combinations of the signal coefficients are taken instead of directly sampling the signal. Many compressed sensing recovery algorithms have been proposed, ranging from convex relaxation techniques to greedy approaches such as Orthogonal Matching Pursuit (OMP) [5] to iterative thresholding schemes such as Iterative Hard Thresholding (IHT) [6, 7]. IHT is proposed for compressed sensing recovery of sparse signals when the sparsity number of the signal is known. In [8], normalized IHT algorithm is proposed which is a stabilized version of IHT. In [2, 9], the Iterative Method with Adaptive Thresholding (IMAT) is proposed to recover the signal from its random samples. The random samples in this case are random selection of the signal entries. The IMAT recovers the underlying sparse signal by alternating projections between the information domain and the sparsity domain (the domain

in which the signal is sparse). In order to take advantage of the sparsity of the embedded signal, IMAT thresholds adaptively the signal (by decreasing or increasing the threshold levels) in such a way that the coefficients are picked up gradually after some iterations. In this paper, two methods are proposed which address the random sampling and CS recovery problems. The proposed random sampling recovery method is the Iterative Method with Adaptive Thresholding and Interpolation (IMATI) which is a modified version of the IMAT. At each iteration, a crude reconstruction of the signal based on linear interpolation is obtained. The adaptive thresholding scheme is exploited to promote sparsity. The proposed compressed sensing recovery method is Iterative Method with Adaptive Thresholding for Compressed Sensing recovery (IMATCS). We note that IMATCS is closely related to IHT method [6, 7], except that the thresholding function is adaptive, i.e., the threshold value changes with the iteration number, which enables IMATCS to reconstruct the sparse signal without having any knowledge of the sparsity number. The simulation results indicate that the IMATI method outperforms the IMAT method. Also, we conclude that random sampling recovery (using IMAT or IMATI) is a good choice for signal compression compared to CS recovery techniques such as Orthogonal Matching Pursuit (OMP), and there is no need to add more complexity to take linear combination of the signal coefficients. However, in some applications the linear combinations of the signal coefficients are imposed by the problem. In such cases, the compressed sensing recovery techniques are the only solution. The simulation results indicate that IMATCS provides better and faster reconstruction compared to normalized IHT, although IHT has an extra information of the sparsity number. Also, the recovery performance of IMATCS is better than that of OMP with less computational complexity.

The rest of the paper is organized as follows: The IMATCS method is proposed in Section II. The proposed IMATI method is presented in section III. The simulation results are given in Section IV. Finally, Section V concludes this work.

II. ITERATIVE METHOD FOR COMPRESSED SENSING RECOVERY (IMATCS)

In this section, the proposed Iterative Method for Compressed Sensing recovery (IMATCS) is illustrated. Let S be $M \times 1$ signal and Φ be $L \times M$ ($L > M$) measurement matrix. The problem is to recover S from its measurement vector $Y = \Phi \times S$ with the constraint that S is sparse in the Ψ domain, $S = \Psi \times X$. In other words, the coefficient vector X has a small number of non-zero entries. The transformation matrix, can be DCT, DWT or DFT. The IMATCS method can be considered as a variant of IHT based on adaptive thresholding. The mathematical formulation of the method is as follows:

$$x_{k+1} = T(x_k + \alpha A^H(Y - A \times x_k)) \quad (1)$$

$$A = \Phi \times \Psi \quad (2)$$

$$S_{recovered} = \Psi \times x_{itermax} \quad (3)$$

λ is the relaxation parameter which controls the convergence of the algorithm. T is the thresholding function decreased iteration by iteration in an exponential manner as follows:

$$T = T_0 \times \exp(-\alpha \times K) \quad (4)$$

where K is the iteration number and λ indicates the threshold step and is determined empirically. The algorithm starts from zero initial value, $x_0 = 0$. After a number of iterations, indicated by $itermax$, the coefficient vector is recovered as $x_{itermax}$. The adaptivity of the threshold enables us to recover the embedding signal from its linear measurements without any knowledge of the sparsity number of the signal.

III. ITERATIVE METHOD WITH ADAPTIVE THRESHOLDING AND INTERPOLATION (IMATI)

Another problem which is addressed here is the recovery of the sparse signal from a random selection of its entries, i.e. random sampling. The proposed method in this case is IMATI which rely on some modifications to the well-known iterative method [10]. The conventional iterative method has originally been proposed in the field of non-uniform sampling recovery for low pass or high pass signals (a special kind of sparse signals). In order to promote sparsity, a thresholding operator is used at the end of each iteration. In random sampling, the measurements are a subset of signal entries. Hence, the random sampling measurement matrix, Φ_R , consists of a random selection of the rows of the identity matrix. The formulation of the IMATI method is given as:

$$x_{k+1} = T(x_k + \times Interpl(Y - A_R \times x_k)) \quad (5)$$

$$A_R = \Phi_R \times \Psi \quad (6)$$

$$S_{recovered} = \Psi \times x_{itermax} \quad (7)$$

The above formulation of IMATI shows the analogy of the two proposed methods, IMATCS and IMATI. A crude reconstruction scheme is used successively and the recovered signal at each iteration is sparsified using an adaptive threshold. In IMATCS method, the measurements are linear combinations of the signal entries and the iterated recovery is based on the transpose of the matrix, i.e. AH. In IMATI, a random selection of the signal entries is available as measurements and the crude reconstruction scheme is based on linear interpolation. Furthermore, in order to promote sparsity, exponential adaptive thresholding is used in the proposed methods. The IMATI method can be implemented in a more efficient way according to the block diagram depicted in Figure 1.

The G operator applies the sampling and interpolation. The random sampling scheme can be implemented by an inner product of the image with a binary sampling mask. Moreover, the linear interpolation can be applied to the sampled image using a sliding interpolating window. Therefore, the above implementation enables IMATI to process the whole image at once.

IV. SIMULATION RESULTS

In this part, the simulation results are reported. The parameters of IMATI method are set as: $T_0 = 66363$, $\alpha = 0.6$, $\lambda = 1.8$, $itermax=35$. The parameters of IMATCS are set as follows: $T_0 = 900$, $\alpha = 0.2$, $\lambda = 0.3$, $itermax=100$.

Two kinds of interpolators have been exploited in IMATI method:

- Linear interpolation using sliding window 3×3

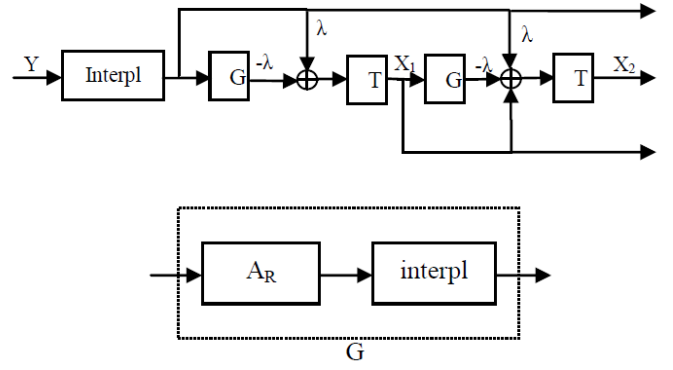

Fig. 1. Block diagram of IMATI method.

The missing pixel is replaced by a weighted average of the 3×3 neighbors. The IMATI method in this case is named IMATLI.

- Sample and hold interpolation

the missing pixels are replaced by their neighboring samples in the top or left. The IMATI method in this case is called IMATSH.

In the case of random sampling recovery methods such as IMAT, IMATSH and IMATLI, the whole of the image is processed at once without dividing it into small blocks, while 8×8 blocks of the image are processed separately for compressed sensing recovery methods such as OMP, normalized IHT and IMATCS. The performances of IMATLI, IMATSH, IMAT and OMP methods are compared in Figure 2.

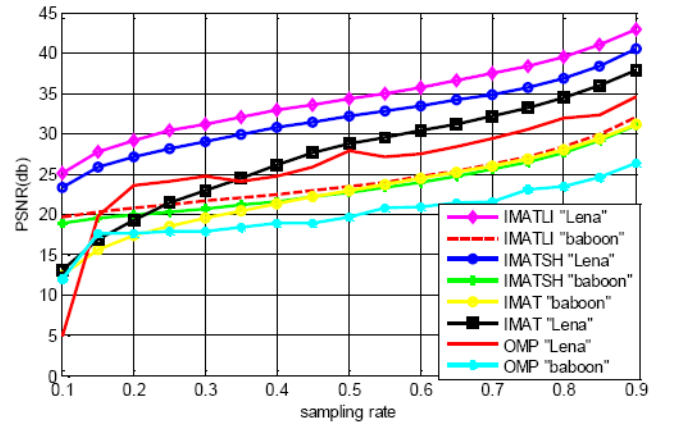

Fig. 2. comparison of IMATI method with IMAT and OMP

According to Figure 2, the IMATLI method has better recovery performance than the IMATSH and both of them outperform IMAT. The OMP method has the worst recovery performance among the all. The simulation time of the methods are compared in Figure 3 as a trustable complexity measure.

Comparing the simulation times of the methods, we observe that IMAT is much more complex than IMATLI and IMATSH especially for lower sampling rates. Furthermore, the IMATSH is faster than IMATLI. The simulation time of OMP goes up as the sampling rate increases and its complexity is more than those of IMAT and IMATSH especially for higher sampling rates. The IMATCS method

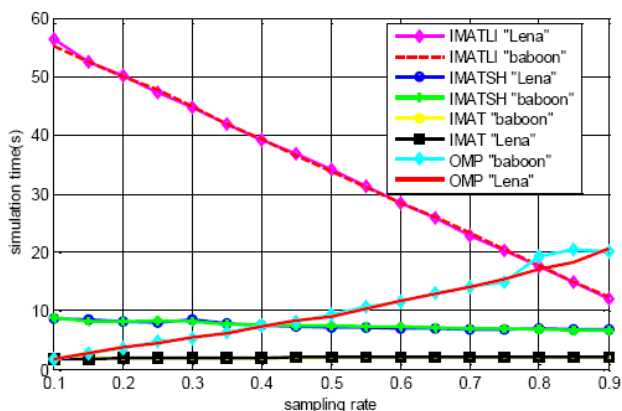

Fig. 3. simulation time of IMATLI, IMATSH, IMAT and OMP

is compared to some well known compressed sensing recovery methods such as OMP [5] and normalized IHT [8] in the case of natural image recovery. As the IHT method requires the signal to be k -sparse for efficient performance, we sparsify the image in the DCT domain up to 20 %. However, for the other two simulated methods (OMP and proposed IMATCS), the original (non-sparse) image is used. The efficiency of the recovery methods for various sampling rates are compared at Figure 4.

Having a look at Figure 4, we understand that the performance

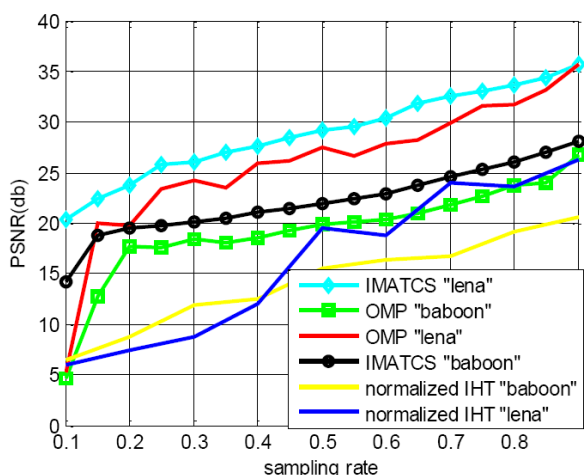

Fig. 4. recovery performance of IMATCS, OMP and normalized IHT

of IMATCS is similar to that of OMP and much better than that of normalized IHT for various sampling rates. To compare the complexities of the methods, the simulation time is shown in Figure 5.

According to Figure 5, the simulation time of normalized IHT is more than 50 times those of OMP and IMATCS. Furthermore, simulation time of OMP increases with the sampling rate while IMATCS has an approximately steady low simulation time. Consequently, the complexity of IMATCS is low and does not change for various sampling rates which can be an excellent characteristic from practical point of view, since a fixed and flexible implementation test bed can be used for various sampling rates.

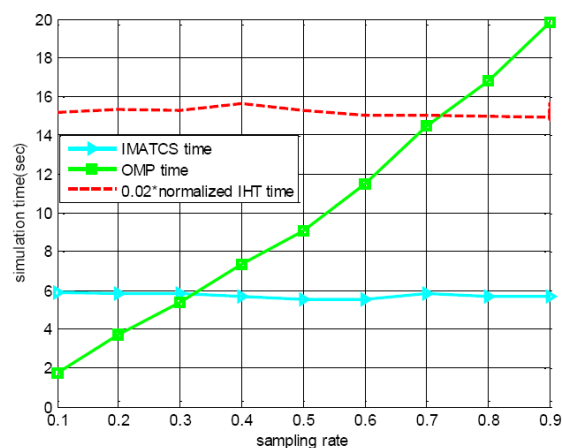

Fig. 5. simulation time of IMATCS, OMP and normalized IHT

V. CONCLUSION

In the case of IMATI method, the linear interpolation performs slightly better than sample and hold interpolation at the cost of more complexity. The IMATSH and IMATLI methods reconstruct the signal better than what IMAT does at the cost of more simulation time. Furthermore, the random sampling recovery techniques including IMAT and IMATI methods, outperform OMP (CS recovery technique) in both simplicity and recovery performance. Also, they exploit the spatial correlations in the 2-D image by taking 2-D DCT transform of the image and it is unnecessary to divide the whole image into small blocks as required in OMP. As a result, for the purpose of signal compression, one does not need a compressive matrix to take linear measurements of the signal coefficients and it is shown in this work that direct random sampling recovery (using IMAT and IMATI) performs better than compressive sampling recovery using OMP. However, when we are faced with an ill-posed system of equations (which inherently has the linear combinations of signal coefficients for example, in MRI imaging), compressed sensing recovery techniques are the only solutions. The simulation results indicate that the proposed CS recovery technique, IMATCS, outperforms IHT in both recovery performance and computational complexity without any need to have knowledge of the sparsity number. Moreover, IMATCS surpasses OMP in terms of recovery performance and convergence speed.

REFERENCES

- [1] F. Marvasti, *Nonuniform Sampling: Theory and Practice*, Springer, formerly Kluwer Academic/Plenum Publishers, 2001.
- [2] F. Marvasti, A. Amini, F. Haddadi, et al, *A Unified Approach to Sparse Signal Processing*, EURASIP Journal on Advances in Signal Processing, 2012.
- [3] E. J. Candes, J. K. Romberg, and T. Tao, *Stable signal recovery from incomplete and inaccurate measurements*, Communications on Pure and Applied Mathematics, Vol.59, No.8, 2006.
- [4] D. L. Donoho, *Compressed sensing*, IEEE Transaction on Information Theory, Vol.52, No.4, 2006.
- [5] A. Tropp and A. C. Gilbert, *Signal recovery from partial information via orthogonal matching pursuit*, IEEE Transaction on Information Theory, Vol.53, No.12, 2007.
- [6] T. Blumensath and M. E. Davies, *Iterative thresholding for sparse approximations*, Journal of Fourier Analysis and Applications, Vol.14, No.5, 2008.
- [7] M. Fornasier and H. Rauhut, *Iterative Thresholding Algorithms*, Journal of Fourier Analysis and Applications, Vol.14, No.5, 2008.

- [8] T. Blumensath and M. Davies *Normalized Iterative Hard Thresholding: Guaranteed Stability and Performance* IEEE Journal of Selected Topics in Signal Processing, Vol. 4, No. 2, 2010.
- [9] R. Eghbali , A. Kazerooni , A. Rashidinejad and F. Marvasti, *Iterative method with adaptive thresholding for sparse signal reconstruction*, International Workshop on Sampling Theory and Applications (SampTA) , Singapore, May 2011.
- [10] F. Marvasti, *An iterative method to compensate for the interpolation distortion*, IEEE Transactions on Acoustics, Speech and Signal Processing , Vol. 37, No. 10, 1989.