

MATHEMATICAL QUESTIONS

Question 1

Exploit the symmetry of the circuit to find i_1 in Fig. 1.

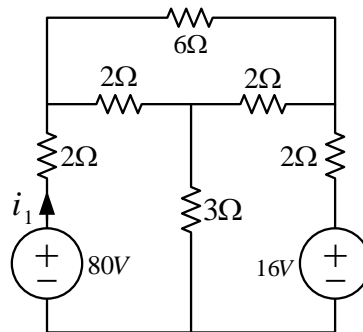

Figure 1: A resistive network.

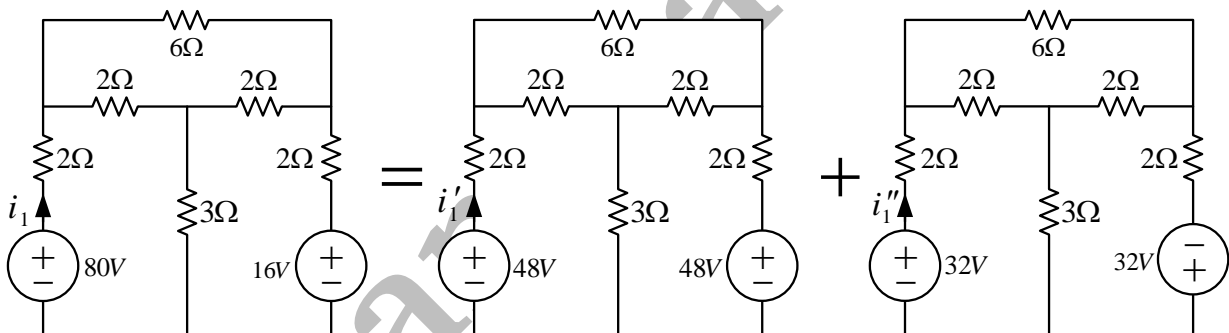

Figure 2: The circuit of Fig. 1 as the superposition of two symmetric circuits.

As shown in Fig. 2, the circuit can be considered as the superposition of two symmetric networks, one with positive symmetry and the other with negation symmetry. So,

$$i = i' + i'' = \frac{48}{2 + 2 + 6} + \frac{32}{2 + 2 || 3} = \frac{48}{10} + \frac{32}{3.2} = 4.8 + 10 = 14.8$$

Question 2

For the circuit of Fig. 3, determine all four nodal voltages using node analysis.

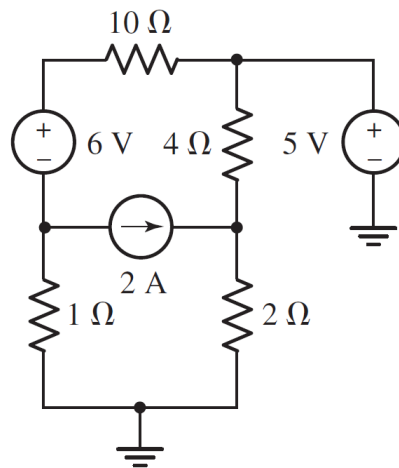

Figure 3: A resistive circuit for which node analysis is desired.

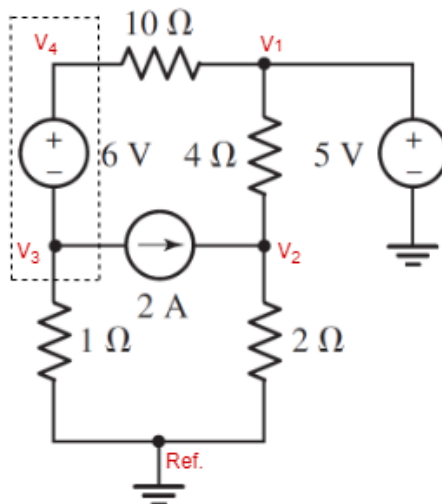

Figure 4: Annotation of the circuit of Fig. 3.

Considering the labeled voltages in Fig. 4,

$$\begin{cases} v_1 = 5 \\ v_4 - v_3 = 6 \\ \frac{v_2 - v_1}{4} + \frac{v_2 - 0}{2} - 2 = 0 \\ \frac{v_3 - 0}{1} + \frac{v_4 - v_1}{10} + 2 = 0 \end{cases} \Rightarrow \begin{cases} v_4 - v_3 = 6 \\ \frac{v_2}{4} + \frac{v_2}{2} = 3.25 \\ v_3 + \frac{v_4}{10} = -1.5 \end{cases}$$

$$\Rightarrow \begin{cases} \frac{v_2}{4} + \frac{v_2}{2} = 3.25 \\ v_3 + \frac{v_3}{10} = -2.1 \end{cases} \Rightarrow \begin{cases} v_1 = 5 \\ v_2 = 4.3 \\ v_3 = -1.9 \\ v_4 = 4.1 \end{cases}$$

Question 3

Calculate the three mesh currents labeled in the circuit diagram of Fig. 5.

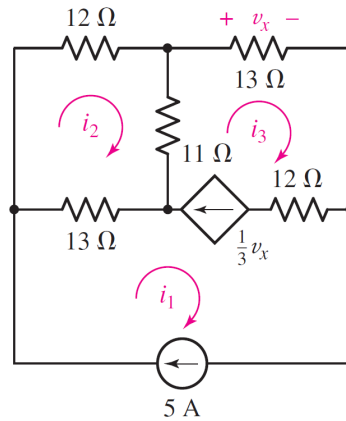

Figure 5: A resistive circuit for which mesh analysis is desired.

Mesh 1 includes the 5 A independent current source, so:

$$i_1 = 5$$

The dependent current source shares mesh 1 and mesh 3, so,

$$i_3 - i_1 = i_3 - 5 = \frac{1}{3}v_x = \frac{1}{3}(13i_3) \Rightarrow i_3 = -1.5$$

Applying KVL in mesh 2,

$$12i_2 + 11(i_2 - i_3) + 13(i_2 - i_1) = 0$$

Finally, we have

$$\begin{cases} i_1 = 5 \\ i_3 - i_1 = \frac{13}{3}i_3 \\ 12i_2 + 11(i_2 - i_3) + 13(i_2 - i_1) = 0 \end{cases} \Rightarrow \begin{cases} i_1 = 5 \\ i_3 = -1.5 \\ i_2 = 1.347 \end{cases}$$

Question 4

Determine the Thevenin and Norton equivalents of the circuit shown in Fig. 6, as seen by an unspecified element connected between terminals a and b.

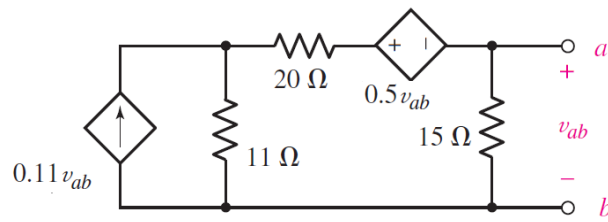

Figure 6: A simple network for which Thevenin and Norton equivalents are required.

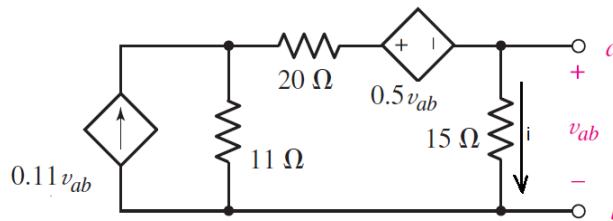

Figure 7: The circuit configuration for finding v_{oc} .

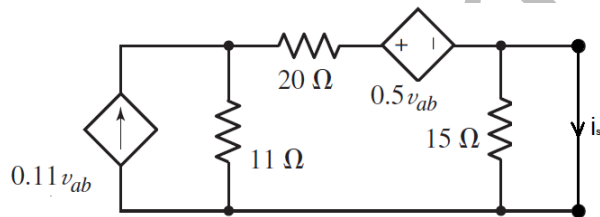

Figure 8: The circuit configuration for finding i_{sc} .

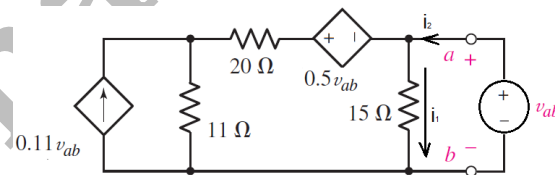

Figure 9: The circuit configuration for finding R_{th} .

As can be interpreted from Fig. 7,

$$i = \frac{v_{ab}}{15}$$

Further, a KVL at the right side loop yields

$$-15i - 0.5v_{ab} - 20i + 11(0.11v_{ab} - i) = 0 \Rightarrow 0.71v_{ab} - 46i = 0$$

Hence,

$$0.71v_{ab} - 46\frac{v_{ab}}{15} = 0 \Rightarrow v_{oc} = v_{ab} = 0$$

Now, consider the circuit shown Fig. 8. Because the output terminals are short circuit, we have $v_{ab} = 0$ and hence, the dependent voltage source and the dependent current source will be short circuit and open circuit respectively. Therefore, $i_{sc} = 0$

Finally, noting to Fig. 9,

$$i_1 = \frac{v_{ab}}{15}, \quad v_{ab} + 0.5v_{ab} - 20(i_2 - i_1) - 11(0.11v_{ab} + i_2 - i_1) = 0$$

, which gives

$$\Rightarrow v_{ab} \approx 13.15i_2 \Rightarrow R_{th} = \frac{v_{ab}}{i_2} \approx 13.15$$

Finally, the circuit can be replaced with an equivalent resistor of 13.15 Ω .

Question 5

Consider the diode circuit in Fig. 10, where $R_1 = R_2 = R_3 = 100 \Omega$, $V_s = 10$, and $v_s(t) = 0.1 \sin(t)$. The diode characteristic curve is described by $i = I_s(e^{\frac{v}{V_T}} - 1)$, where the reverse bias saturation current $I_s = 25 \text{ nA}$ and the thermal voltage $V_T = 25.852 \text{ mV}$.

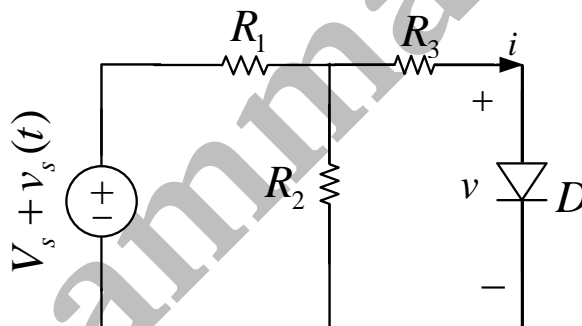

Figure 10: A nonlinear circuit with diode.

(a) Plot the characteristic curve of the diode and approximate its forward voltage V_D .

The characteristic of the diode is shown in Fig. 11.

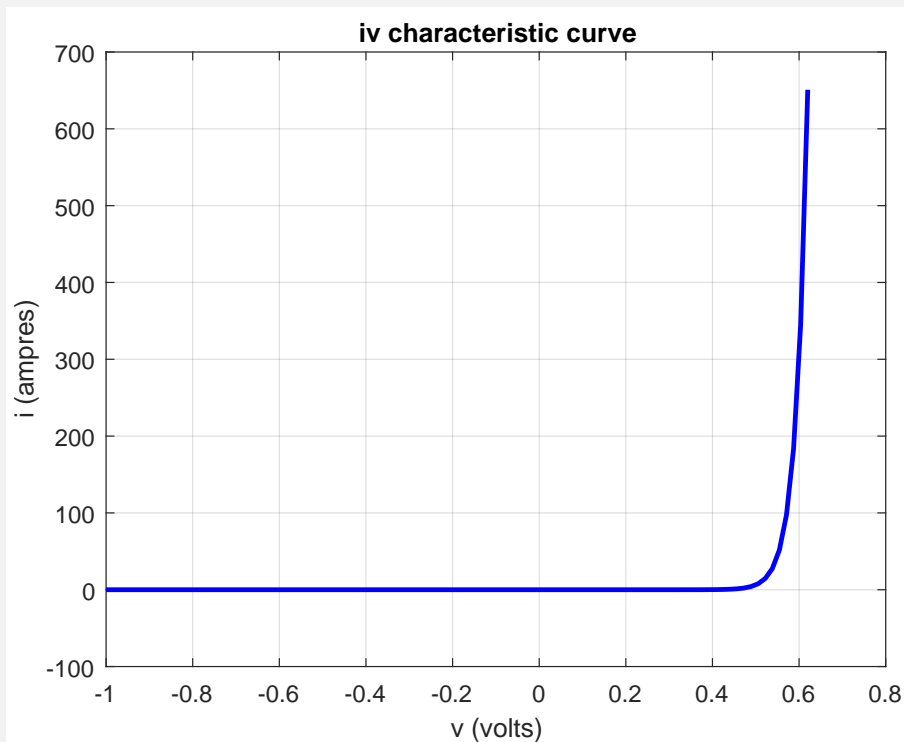

Figure 11: iv characteristic curve of the diode.

We can see that near $V_D \approx 0.6$ V, the curve is almost vertical. So, in forward bias, we have the forward voltage $V_D \approx 0.6$ V approximately.

(b) Find the Thevenin equivalent circuit seen from the diode.

Open circuit voltage:

$$V_{oc} = \frac{R_2}{R_1 + R_2} (V_s + v_s(t)) = 5 + 0.05 \sin(t) \text{ V}$$

Short circuit current:

$$I_{sc} = \frac{V_s + v_s(t)}{R_3 || R_2 + R_1} \times \frac{R_2}{R_2 + R_3} = 33.33 + 0.33 \sin(t) \text{ mA} \quad (1)$$

Equivalent resistor:

$$R_{th} = \frac{V_{oc}}{I_{sc}} = \frac{R_1 R_2 + R_1 R_3 + R_2 R_3}{R_1 + R_2} = R_3 + R_1 || R_2 = 150 \Omega \quad (2)$$

(c) Find the voltage V and the current I of the operating point of the diode.

Substituting the linear part of the circuit with its Thevenin equivalent, we get

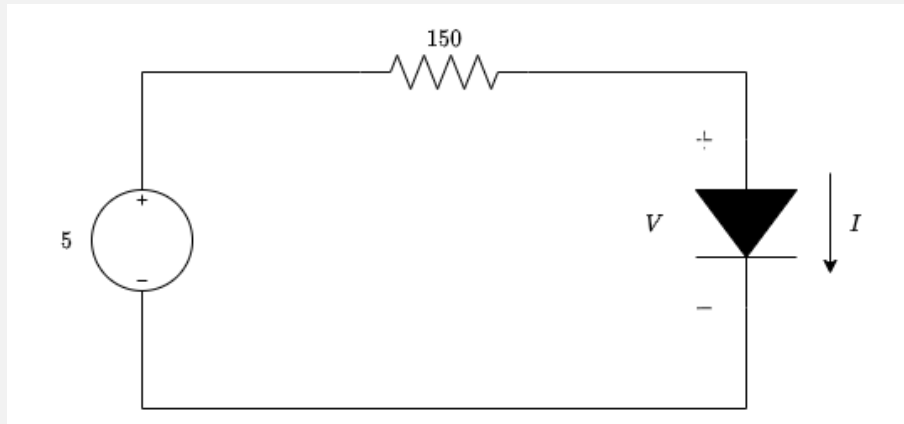

Figure 12: Calculation of the operating point.

In order to find the operating point, we only consider the DC term of V_{th} . Now, we have,

$$\begin{cases} V = 5 - 150I \\ I = I_s(e^{\frac{V}{V_T}} - 1) \end{cases}$$

This set of nonlinear equations can be solved numerically to yield the operating point as $I = 30.9 \text{ mA}$ and $V = 0.3626 \text{ V}$.

(d) Find the small signal model of the circuit and use it to calculate $i(t)$ and $v(t)$ when the circuit is supplied by $V_s + v_s(t)$.

$$i = I_s(e^{\frac{v}{V_T}} - 1) \Rightarrow g_d = \left. \frac{di}{dv} \right|_{v=V} = \frac{I_s}{V_T} e^{\frac{V}{V_T}}$$

So,

$$g_d = 1.19436 \Rightarrow r_d = 0.8378 \Omega$$

So the small signal model of the circuit is

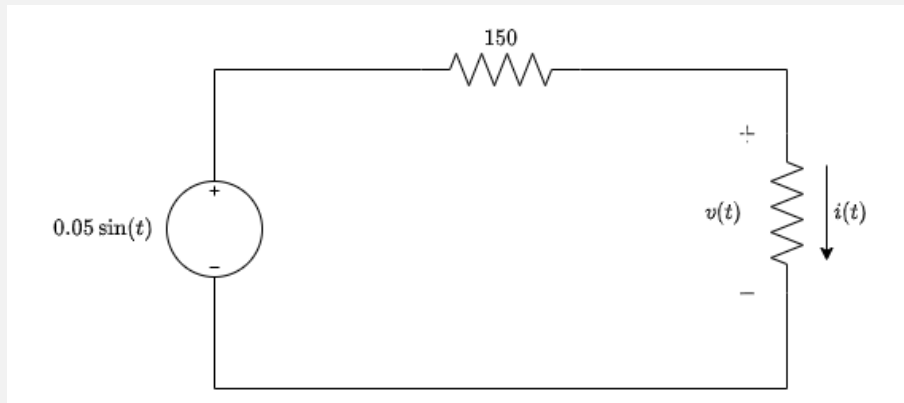

Figure 13: Small signal model of the circuit

Thus

$$i_{ss}(t) = \frac{0.05 \sin(t)}{150 + 0.8378} = 0.3314 \sin(t) \text{ mA}$$

$$v_{ss}(t) = \frac{0.8378}{0.8378 + 150} \times 0.05 \sin(t) = 0.277 \sin(t) \text{ mV}$$

Finally,

$$v(t) = V + v_{ss}(t) = 0.3626 + 0.277 \sin(t) \text{ mV}$$

$$i(t) = I + i_{ss}(t) = 30.9 + 0.3314 \sin(t) \text{ mA}$$

(e) How do the values I and V differ from their corresponding values obtained for ideal diode model?

For the ideal diode, the forward voltage is $V_D = 0$. So,

$$V = 0 \text{ V}, \quad I = \frac{5}{150} = 33.33 \text{ mA}$$

, which is a good approximation for the exact operating point with $V = 0.3626 \text{ V}$ and $I = 30.9 \text{ mA}$.

Question 6

Find the characteristic curve of the diode circuit shown in Fig. 14.

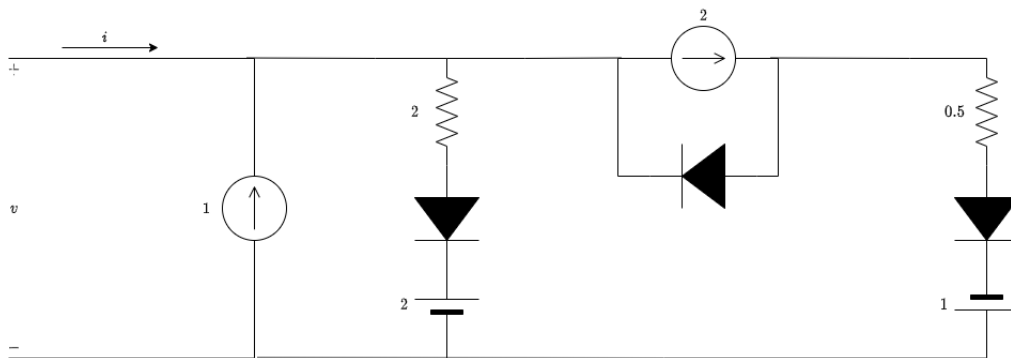

Figure 14: A circuit with three ideal diode.

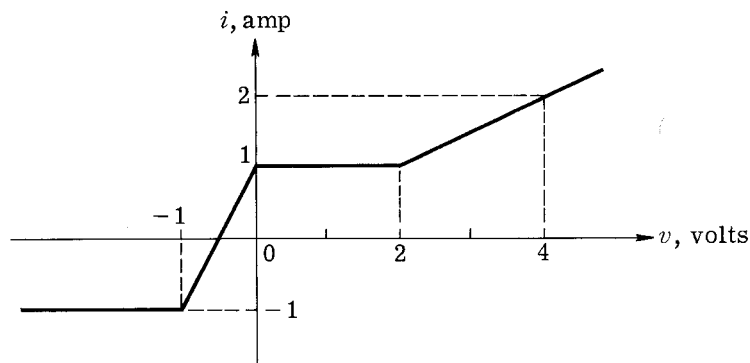

Figure 15: The characteristic curve of the one-port shown in Fig. 14.

Let D_1 , D_2 , and D_3 denote the diodes from the left to right. We have three ideal diodes and 8 cases as follows.

1. D_1 :off, D_2 :off, D_3 :off
KCL law is violated.
2. D_1 :on, D_2 :off, D_3 :off
KCL law is violated.
3. D_1 :off, D_2 :on, D_3 :off

$$i = -1$$

$$v_{D1} = v - 2 \leq 0 \Rightarrow v \leq 2$$

$$i_{D2} = 2 \geq 0$$

$$v_{D3} = v + 1 \leq 0 \Rightarrow v \leq -1$$

So for $v \leq -1$, $i = -1$.

4. D1:off, D2:off, D3:on

$$i = -1 + 2 = 1$$

$$v_{D1} = v - 2 \leq 0 \Rightarrow v \leq 2$$

$$v_{D2} = 1 - 1 - v \leq 0 \Rightarrow v \geq 0$$

$$i_{D3} = 2 \geq 0$$

So for $0 \leq v \leq 2, i = 1$.

5. D1:off, D2:on, D3:on

$$i = \frac{v+1}{0.5} - 1$$

$$v_{D1} = v - 2 \leq 0 \Rightarrow v \leq 2$$

$$i_{D2} = 2 - \frac{v+1}{0.5} \geq 0 \Rightarrow v \leq 0$$

$$i_{D3} = \frac{v+1}{0.5} \geq 0 \Rightarrow v \geq -1$$

So for $-1 \leq v \leq 0, i = 2v + 1$.

6. D1:on, D2:on, D3:off

$$i = \frac{v-2}{2} - 1$$

$$i_{D1} = \frac{v-2}{2} \geq 0 \Rightarrow v \geq 2$$

$$i_{D2} = 2 \geq 0$$

$$v_{D3} = v + 1 \leq 0 \Rightarrow v \leq -1$$

, which is infeasible.

7. D1:on, D2:off, D3:on

$$i = \frac{v-2}{2} - 1 + 2$$

$$i_{D1} = \frac{v-2}{2} \geq 0 \Rightarrow v \geq 2$$

$$v_{D2} = 1 - 1 - v \leq 0 \Rightarrow v \geq 0$$

$$i_{D3} = 2 \geq 0$$

So for $v \geq 2, i = \frac{v}{2}$.

8. D1:on, D2:on, D3:on

$$i = \frac{v+1}{0.5} - 1$$

$$i_{D1} = \frac{v-2}{2} \geq 0 \Rightarrow v \geq 2$$

$$i_{D2} = 2 - \frac{v+1}{0.5} \geq 0 \Rightarrow v \leq 0$$

$$i_{D3} = \frac{v+1}{0.5} \geq 0 \Rightarrow v \geq -1$$

, which is infeasible. Finally,

$$i = \begin{cases} -1, & v \leq -1 \\ 2v + 1, & -1 \leq v \leq 0 \\ 1, & 0 \leq v \leq 2 \\ \frac{v}{2}, & v \geq 2 \end{cases}$$

The corresponding characteristic curve is shown in Fig. 15.

SOFTWARE QUESTIONS

Question 7

Employ PSpice DC sweep simulation to obtain the characteristic curve of the circuit shown in Fig. 14 in a more realistic scenario, where real 1N4148 diodes are used. Is there any difference between the characteristic curves obtained by the simulation and analysis? Investigate the impact of the temperature on the circuit performance using temperature sweep simulation.

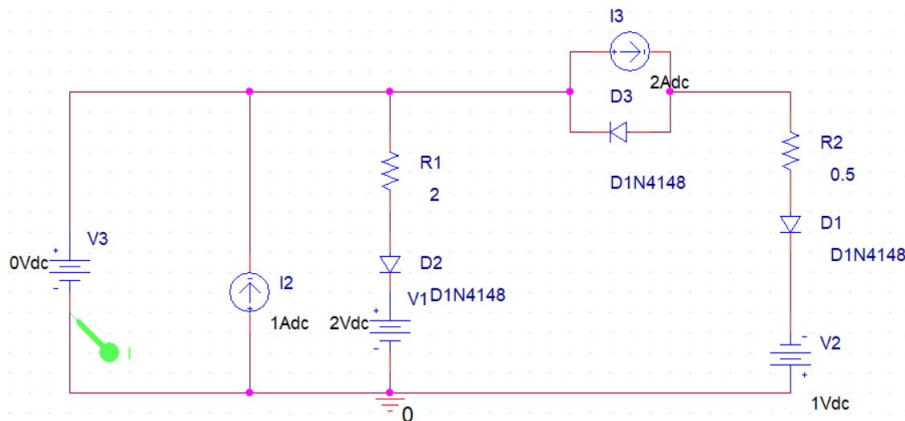

Figure 16: Circuit schematic.

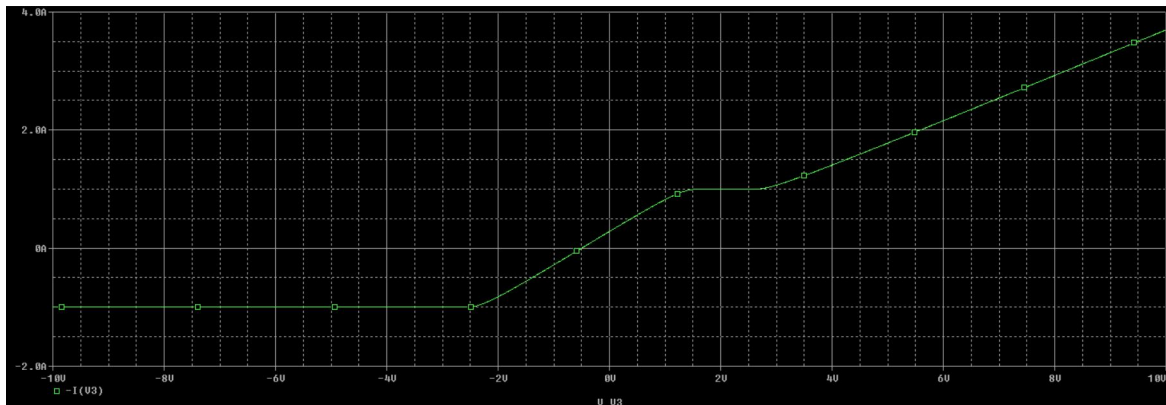

Figure 17: i_v characteristic curve.

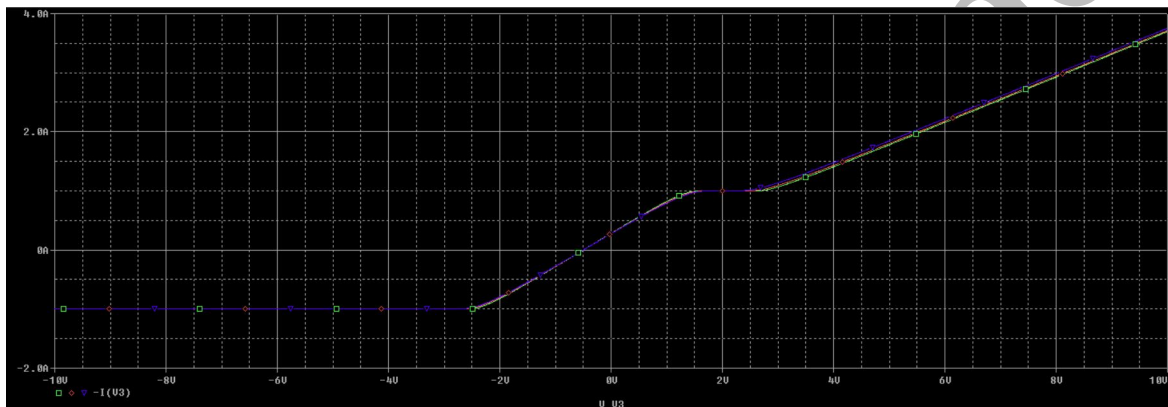

Figure 18: i_v characteristic curve for various temperatures. (green) 27°C, (red) 100°C, (blue) 200°C.

Fig. 16 illustrates the schematic of the circuit and Fig. 17 shows the corresponding simulated i_v curve. There is a mismatch between the analytical and simulation results that is mainly resulted from the non-zero forward voltage of the 1N4148 diodes. As shown in Fig. 18, increasing the temperature, the characteristic curve shifts up due to the temperature-dependent behavior of the diode.

BONUS QUESTIONS

Question 8

Return your answers by filling the \LaTeX template of the assignment.

EXTRA QUESTIONS

Question 9

Feel free to solve the following questions from the book *“Engineering Circuit Analysis”* by W. Hayt, J. Kemmerly, and S. Durbin.

1. Chapter 4, question 11.
2. Chapter 4, question 12.
3. Chapter 4, question 13.
4. Chapter 4, question 13.
5. Chapter 4, question 18.
6. Chapter 4, question 22.
7. Chapter 4, question 34.
8. Chapter 4, question 35.
9. Chapter 4, question 44.
10. Chapter 4, question 45.
11. Chapter 5, question 13.
12. Chapter 5, question 18.
13. Chapter 5, question 30.
14. Chapter 5, question 31.
15. Chapter 5, question 50.
16. Chapter 5, question 60.
17. Chapter 5, question 66.